



Technical Specification for Optical Transceiver Module

SCM6008-GL

- | | | |
|--|---|--|
| <input type="checkbox"/> 155.52Mbps | <input type="checkbox"/> 622.08Mbps | <input checked="" type="checkbox"/> other <u>2488.32Mbps</u> |
| <input checked="" type="checkbox"/> Short Haul | <input type="checkbox"/> Long Haul | <input type="checkbox"/> other _____ |
| <input type="checkbox"/> Intermediate Reach | <input type="checkbox"/> Long Reach | <input type="checkbox"/> other _____ |
| <input type="checkbox"/> Single 5.0 V | <input checked="" type="checkbox"/> Single 3.3 V | <input type="checkbox"/> other _____ |
| <input checked="" type="checkbox"/> 1.3 μm | <input type="checkbox"/> 1.55 μm | <input type="checkbox"/> other _____ |
| <input type="checkbox"/> Transmitter | <input type="checkbox"/> Receiver | <input checked="" type="checkbox"/> Transceiver |
| | (<input type="checkbox"/> 2R / <input type="checkbox"/> 3R) | (<input checked="" type="checkbox"/> 2R / <input type="checkbox"/> 3R) |

Applicable Part Numbers : SCM6008-GL-ZN, SCM6008-GL-CN



Sumitomo Electric reserves the right to make changes in this specification without prior notice.

#Safety Precaution Symbols This specification uses various picture symbols to prevent possible injury to operator or other persons or damage to properties for appropriate use of the product. The symbols and definitions are as shown below. Be sure to be familiar with these symbols before reading this specification.

- | | |
|--|--|
| | Warning Wrong operation without following this instruction may lead to human death or serious injury. |
| | Caution Wrong operation without following this instruction may lead to human injury or property damage. |

Example of picture symbols

indicates prohibition of actions. Action details are explained thereafter.

indicates compulsory actions or instructions. Action details are explained thereafter.

1. General

Features and applications of SCM6008-GL are listed below.

Features

* Multi Bit Rate Operation	155Mbps ~ 2.5Gbps
* Power Supply Voltage	Single +3.3V
* Compact Package Size	49.0 X 13.59 X 9.4 mm
* Electrical Interface	LVPECL for DATA and LVTTTL for Signal Detect and Laser Disable
* Fiber Coupled Power	-5 ~ 0dBm into SMF
* Input Power Range	0 ~ -18dBm
* Monitor Functions	Laser Bias Monitor, Rear Facet Monitor
* Laser Disable Function	
* Signal Detect (SD) Function	
* Connector Interface	LC Duplex Connector

Applications

*Telecommunications	*Data communications
> SONET/IR, SDH/SH Application	>High Speed Rack-to-Rack Data Links
> ATM Application	
> Shelf-to-Shelf Multi Bit Rate Application	
> Subscriber Loop	
> Metropolitan Area Network	

2. Block Diagram

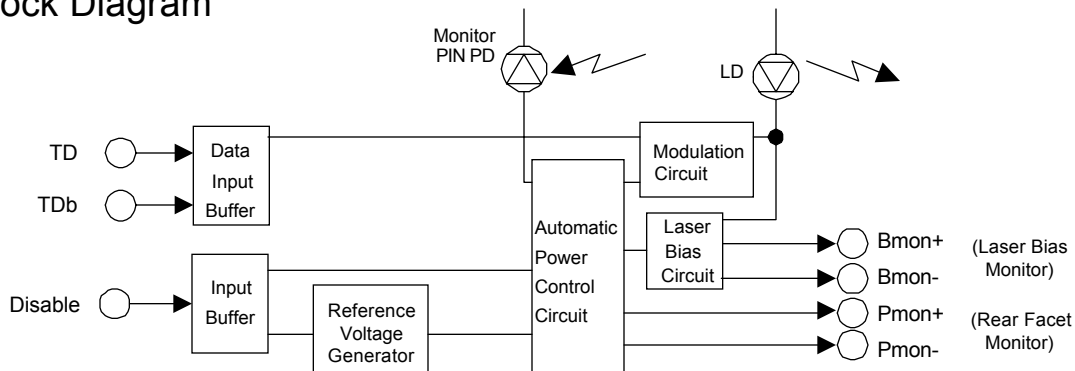

Figure 1-1. Block Diagram (Transmitter)

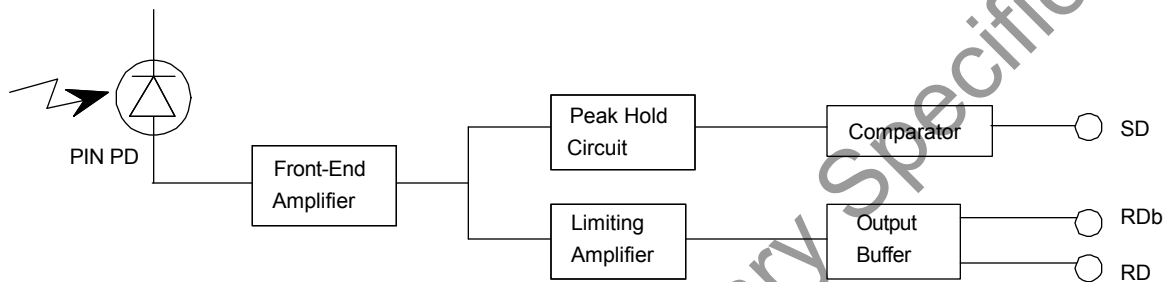

Figure 1-2. Block Diagram (Receiver)

⚠ Caution

- Do not disassemble this product. Otherwise, failure, electrical shock, overheating or fire may occur.
- Handle the lead pins carefully. Use assisting tools or prospective aids as required. A lead pin may injure skin or human body.

3. Package Dimension

All dimensions are in mm.

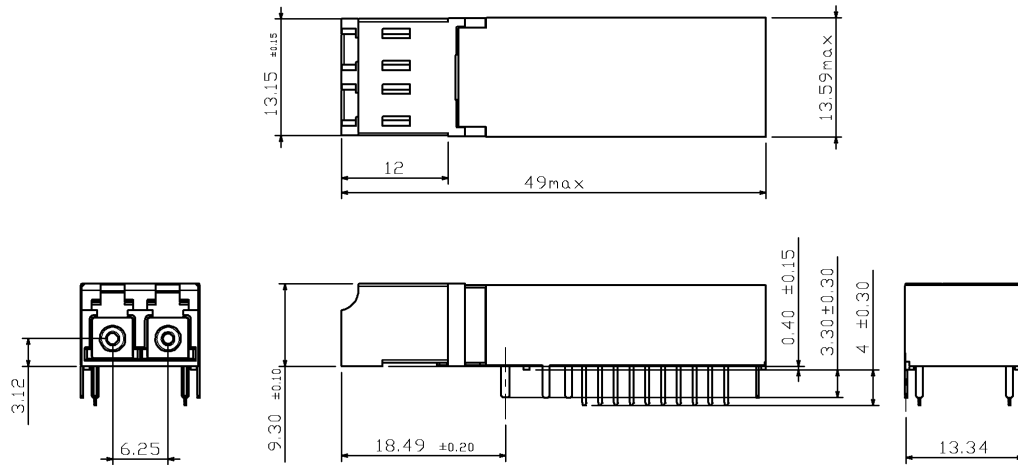

Figure 2-1. Outline Dimensions (SCM6008-GL-ZN)

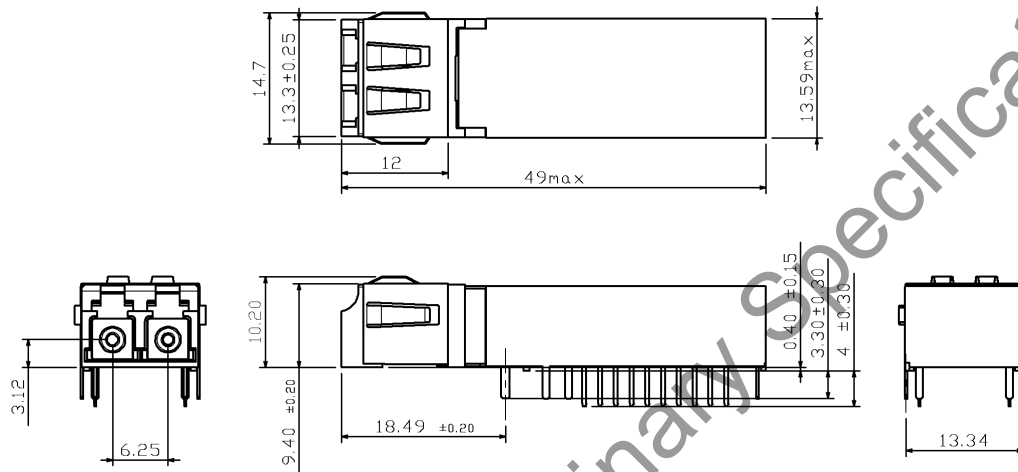

Figure 2-2. Outline Dimensions (SCM6008-GL-CN)

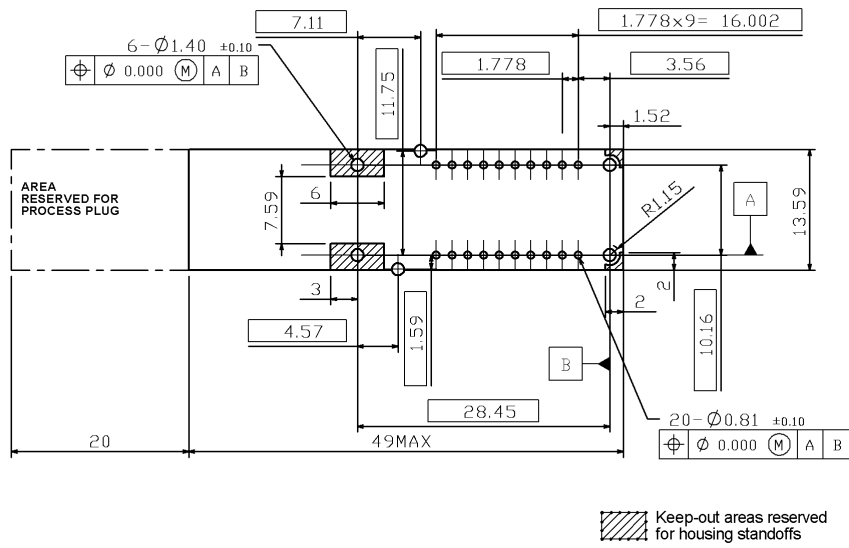

Figure 2-3. Recommended Footprint

Preliminary Specification

4. Pin Assignment

No.	Symbol	I/O/P	Level	Description
1	VpdR	P	+3.3V DC	DC Bias Supply for Receiver PIN-PD.
2	VeeR	P	GND	Power Supply (-) for Receiver.
3	VeeR	P	GND	Power Supply (-) for Receiver.
4	NC			No User Connection.
5	NC			No User Connection.
6	VeeR	P	GND	Power Supply (-) for Receiver.
7	VccR	P	+3.3V DC	Power Supply (+) for Receiver.
8	SD	O	LVTTTL	Signal Detect. High level indicates presence of optical input signal (Active High).
9	RDb	O	LVPECL	Inverted Receiver Output Data. No internal terminations are provided.
10	RD	O	LVPECL	Non-Inverted Receiver Output Data. No internal terminations are provided.
11	VccT	P	+3.3V DC	Power Supply (+) for Transmitter.
12	VeeT	P	GND	Power Supply (-) for Transmitter.
13	Tdis	I	LVTTTL/LVCMOS	Transmitter Disable (Active High). Defaults to logic 0 (enable TX) when left open.
14	TD	I	LVPECL	Non-Inverted Transmitter Input Data. Self biased and internally terminated.
15	TDb	I	LVPECL	Inverted Transmitter Input Data. Self biased and internally terminated.
16	VeeT	P	GND	Power Supply (-) for Transmitter.
17	Bmon-	O	Analog Voltage	LD Bias Current Monitor. Voltage difference between pins 17 and 18 is proportional to the laser bias current.
18	Bmon+	O	Analog Voltage	
19	Pmon-	O	Analog Voltage	Rear Facet Monitor. Transmitter output power can be monitored, in terms of rear facet monitor PD current, by measuring voltage difference between pins 19 and 20.
20	Pmon+	O	Analog Voltage	

Notes:

1. I/O/P stand for signal input, signal output, and DC power/bias supply, respectively.
2. Refer to figure 3 for details of Bmon and Pmon outputs.

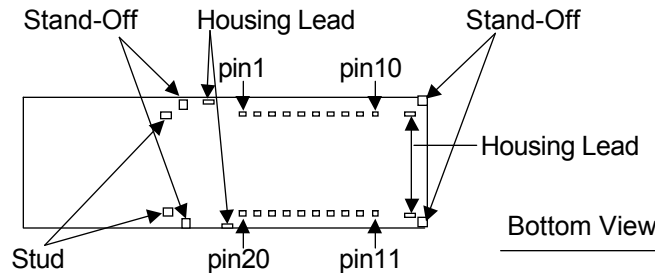

5. Absolute Maximum Ratings

Parameter	Symbol	Min.	Typ.	Max.	Unit	Note
Storage Case Temperature	Ts	-40	-	85	°C	1
Operating Case Temperature	Tc	-5	-	70	°C	1
Supply Voltage	Vcc	0.0	-	4.0	V	
PIN-PD Bias Voltage	VpdR	-	-	7.0	V	
Input Voltage	Vi	0.0	-	Vcc+0.5	V	2
Lead Soldering (Temperature)				260	°C	3
Lead Soldering (Time)				10	sec.	

Notes

1. No condensation allowed.
2. TD, TDb, Disable
3. Measured on lead pin at 2mm (0.079in.) off the package bottom

Warning

⚠ Use the product with the rated voltage described in the specification. If the voltage exceeds the maximum rating, overheating or fire may occur.

Caution

⚠ Do not store the product in the area where temperature exceeds the maximum rating, where there is too much moisture or dampness, where there is acid gas or corrosive gas, or other extreme conditions. Otherwise, failure, overheating or fire may occur.

6. Electrical Interface

(Unless otherwise specified, Vcc = 3.14 to 3.47 V and all operating temperature shall apply.)

6-1. Transmitter side

Parameter	Symbol	Min.	Typ.	Max.	Unit	Note
Supply Voltage	Vcc	3.14	3.30	3.47	V	
Supply Current	ldtx		110	200	mA	1
Differential Input Voltage Swing (TD,TDb)	Vin	0.60		2.00	Vp-p	2
Input Impedance	Rin	75	100	125	Ω	3
Signal Input Rise/Fall Time				120	psec	4

Notes

1. Input bias current is not included. 50% duty cycle data. 2488.32Mbps
2. Vcc=3.3V, Tc=25°C
3. Measured between TD and TDb
4. 20 ~ 80%

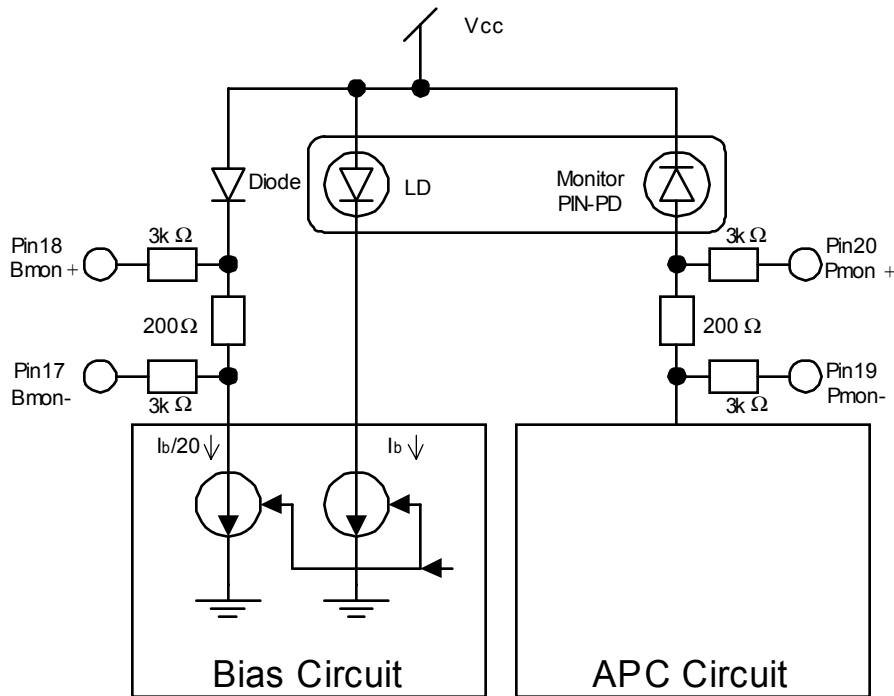

Figure 3. Bmon / Pmon Circuit Detail

6-2. Receiver side

Parameter	Symbol	Min.	Typ.	Max.	Unit	Note
Supply Voltage	Vcc	3.14	3.30	3.47	V	
Supply Current	ldrx		80	130	mA	1
PIN-PD Bias Voltage	VpdR	2.40	3.3	5.25	V	
RD and RDb	High	Vdoh	Vcc-1.10	Vcc-0.65	V	2
Output Voltage	Low	Vdol	Vcc-1.80	Vcc-1.30	V	
SD	High	Vsoh	2.40	Vcc	V	
Output Voltage	Low	Vsol	0.0	0.5	V	
Data Rise / Fall Time	tr / tf		140 / 120		psec	3
SD Assert Time	ta	2.3		100	μ sec	4
SD Deassert Time	td	2.3		350	μ sec	

Notes

1. Output current is not included.
2. Vcc=+3.3V, Tc=25°C, Output load resistance RL=50 Ω to Vcc-2V for RD, RDb.
3. 20~80%, Input capacitance and stray capacitance of measuring devices should be less than 2pF.
4. 2488.32Mbps, PRBS 2²³-1, NRZ

7. Optical Interface

(Unless otherwise specified, Vcc = 3.14 to 3.47 V and all operating temperature shall apply.)

7-1. Transmitter side

Parameter	Symbol	Min.	Typ.	Max.	Unit	Note
Average Output Power	Po	-5.0		0.0	dBm	1
Extinction Ratio	Er	8.2			dB	1
Center Wavelength	λ_c	1260		1360	nm	
Spectral Width (-20dB Width)	$\Delta\lambda$			1	nm	
Side Mode Suppression Ratio	Sr	30			dB	
Eye Mask for Optical Output	Refer to Figure 4					

Note 1. Measured at 2488.32Mbps PRBS2²³-1, 50% duty cycle, NRZ.

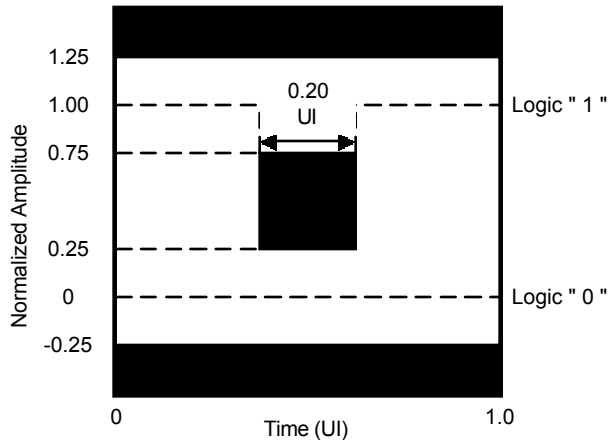

Relation between Input Signal and Optical Output Signal

Input Signal		Optical Output Signal
TD	TDb	
High	Low	ON (High)
Low	High	OFF (Low)
High	High	Undefined
Low	Low	Undefined

Figure 4 Eye Diagram Mask for Optical Output

⚠ Warning

⊘ Do not look at the laser beam projection area (e.g. end of optical connector) with naked eyes or through optical equipment while the power is supplied to this product. Otherwise, your eyes may be injured.

7-2. Receiver side

Parameter	Symbol	min.	Typ.	Max.	Unit	Note
Center Wavelength	-	1260		1360	nm	
Minimum Sensitivity	Pmin			-18.0	dBm	1, 2
Overload	Pmax	0			dBm	1, 2
SD Assert Level	Pa		-22		dBm	2
SD Deassert Level	Pd		-25		dBm	
SD Hysteresis	Phys	0.5	3		dB	
Reflectance	REFr		-14		dB	

Note 1. BER=10⁻¹⁰

2. Measured at 2488.32Mbps, PRBS 2²³-1, NRZ

8. Relation between Disable Input Voltage and Optical Output Power

Disable Input Voltage	Optical Output Power
"L"(0 ~ 0.8V)	Enabled
"H"(2.0V ~ Vcc)	Disabled (<-45dBm)

*Note : Enabled for no Disable input (Pin 13 open)

9. Recommended Interface Circuit

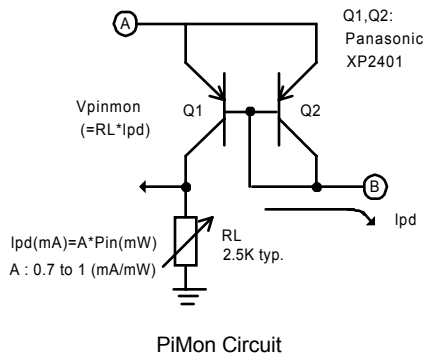
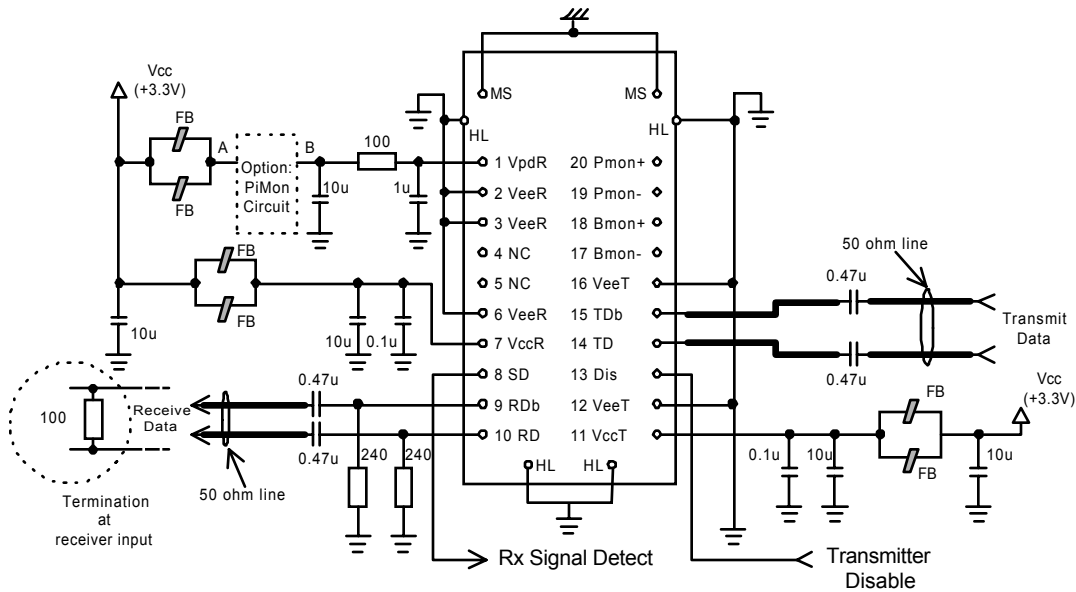

FB : BLM11HA601SG(Murata)

MS : Mounting Stud

HL : Housing Lead

Notes:

- (1) Components on RD/RDb lines, 240Ω and 0.47μ, should be placed as close as possible to module pins.
- (2) Coupling capacitors on RD/RDb and TD/TDb lines, 0.47μF, can be as low as 0.1μF if multi bit rate operation is not needed.
- (3) 0.1μ capacitors on VccR/VccT lines should be as close as possible to module pins.
- (4) 50Ω line pattern and component placements on RD/RDb and TD/TDb lines should be symmetrical for better impedance matching.
- (5) HL is internally connected to VeeR.
- (6) VeeR and VccT are not internally connected to each other.

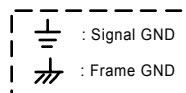

Figure 5. Recommended Interface Circuit

10. Reliability Test Program

GR-468-CORE Issue 1, December 1998 Laser Module

HEADING	TEST	REFERENCE	CONDITIONS	SAMPLING		
				LTPD	SS	C
Mechanical Integrity	Mechanical Shock	MIL-STD-883 Method 2002	5 times/axis 1,500G, 0.5ms	20	11	0
	Vibration	MIL-STD-883 Method 2007	Cond. A 20G, 20-2,000G Hz, 4min/cy, 4cy/axis	20	11	0
	Thermal Shock	MIL-STD-883 Method 1011	Delta T=100°C 0°C to 100°C	20	11	0
	Solderability	MIL-STD-883 Method 2003	(steam aging not required)	20	11	0
Endurance	Accel. Aging (High Temp.)	(R)-4-53 Section 5.18	85°C; rated power 1,000 hrs. for pass/fail 2,000, 5,000 hrs. for info.	-	25 10	-
	Low Temp. Storage	-	min, storage T 1,000 hrs. for pass/fail 2000 hrs. for info.	20	11	0
	Temperature Cycling	Section 5.20	-40°C to +85°C 500 for pass/fail 1,000 for info.	20 -	11 11	0 -
	Damp Heat	MIL-STD-202 Method 103 or IEC-68-2-3	85°C/85%RH 1,000hrs.	20	11	0
	Cyc. Moist., Res.	Sec. 5.23	-	20	11	0
Special Tests	Internal Moisture	MIL-STD-883 Method 1018	Max. 5,000ppm water vapour	20	11	0
	ESD Threshold	Section 5.22		-	6	-

SS : Sample Size

C : Maximum number of failure allowed to pass the test.

11. Laser Safety

This product uses a semiconductor laser system and is a laser class 1 product acc. FDA, complies with 21CFR 1040. 10 and 1040.11. Also this product is a laser class 1 product acc. IEC 60825-1.

 Class 1 Laser Product

⚠ Caution







- ⊘ If this product is used under conditions not recommended in the specification or this product is used with unauthorized revision, classification for laser product safety standard is invalid. Classify the product again at your responsibility and take appropriate actions.

12. Other Precaution

Under such a strong vibration environment as in automobile, the performance and reliability are not guaranteed.

The governmental approval is required to export this product to other countries. To dispose of these components, the appropriate procedure should be taken to prevent illegal exportation.

This module must be handled, used and disposed of according to your company's safe working practice.

 Warning	
	Be sure to carry out correct soldering for connection to peripheral circuits in order to prevent contact failure or short-circuit. Otherwise, a strong laser beam may cause eye injury, overheating or fire.
	Do not put this product or components of this product into your mouth. This product contains material harmful to health.
 Caution	
	Be sure to turn the power off when you touch this product connected to the printed circuit boards. Otherwise, electric shock may occur.
	Dispose this product or equipment including this product properly as an industrial waste according to the regulations.

13. Ordering Information

Ordering Number	Connector Type	EMI Shield Finger Option	Operating Case Temperature
SCM6008-GL-ZN	LC Duplex Receptacle, Metallized	Without Finger	-5°C ~ 70°C
SCM6008-GL-CN	LC Duplex Receptacle, Metallized	With Type-C Finger	

14. For More Information

U.S.A.

Sumitomo Electric Lightwave Corp, 78 Alexander Drive, Research Triangle Park, NC 27709

Tel. +1-919-541-8100 / Fax. +1-919-541-8376

E-mail: info@sumitomoelectric.com

<http://www.sumitomoelectric.com/products/eop>

Europe

Sumitomo Electric Europe Ltd., 220, Centennial Park, Elstree, Herts, WD6 3SL, United Kingdom

Tel. +44-208-953-8681

Fax. +44-208-207-5950

<http://www.sumielectric.com>

Japan

Sumitomo Electric Industries, Ltd. (International Business Division), 3-12, Moto-Akasaka 1-chome
Minato-ku Tokyo 107-8468

Tel. +81-3-3423-5771 / Fax. +81-3-3423-5099

E-mail: product-info@ppd.sei.co.jp

<http://www.sei.co.jp/Electro-optic/index.html>