



# Technical Specification for Optical Transceiver Module

## SCM6011-GL

- |  |   |  |
|--|---|--|
| <input checked="" type="checkbox"/> 155.52Mb/s | <input type="checkbox"/> 622.08Mb/s                           | <input type="checkbox"/> other _____                                     |
| <input type="checkbox"/> Short Haul            | <input checked="" type="checkbox"/> Long Haul                 | <input type="checkbox"/> other _____                                     |
| <input type="checkbox"/> Intermediate Reach    | <input checked="" type="checkbox"/> Long Reach                | <input type="checkbox"/> other _____                                     |
| <input type="checkbox"/> Single 5.0 V          | <input checked="" type="checkbox"/> Single 3.3 V              | <input type="checkbox"/> other _____                                     |
| <input checked="" type="checkbox"/> 1.3 μm     | <input type="checkbox"/> 1.55 μm                              | <input type="checkbox"/> other _____                                     |
| <input type="checkbox"/> Transmitter           | <input type="checkbox"/> Receiver                             | <input checked="" type="checkbox"/> Transceiver                          |
|  | ( <input type="checkbox"/> 2R / <input type="checkbox"/> 3R ) | ( <input checked="" type="checkbox"/> 2R / <input type="checkbox"/> 3R ) |



Sumitomo Electric reserves the right to make changes in this specification without prior notice.

**#Safety Precaution**    **Symbols** This specification uses various picture symbols to prevent possible injury to operator or other persons or damage to properties for appropriate use of the product. The symbols and definitions are as shown below. Be sure to be familiar with these symbols before reading this specification.

	<b>Warning</b> Wrong operation without following this instruction may lead to human death or serious injury.
	<b>Caution</b> Wrong operation without following this instruction may lead to human injury or property damage.

Example of picture symbols

indicates prohibition of actions. Action details are explained thereafter.

indicates compulsory actions or instructions. Action details are explained thereafter.

## 1. General

Features of SCM6011-GL are listed below.

- \* SDH STM-1 L-1.1 / SONET OC-3 LR-1 Compliant
- \* Power Supply Voltage           Single +3.3V
- \* Compact Package Size           49.0 X 13.59 X 9.4 mm
- \* Electrical Interface           LVPECL for DATA, LVTTTL for Signal Detect and Laser Disable
- \* Fiber Coupled Power           0 ~ -5dBm (Typ. -2dBm) into SMF
- \* Input Power Range           -8 ~ -34dBm (Typ. Sensitivity -35dBm)
- \* Monitor Functions           Laser Bias Monitor, Rear Facet Monitor
- \* Laser Disable Function
- \* Signal Detect (SD) Function
- \* Connector Interface           LC Duplex Receptacle

## 2. Block Diagram

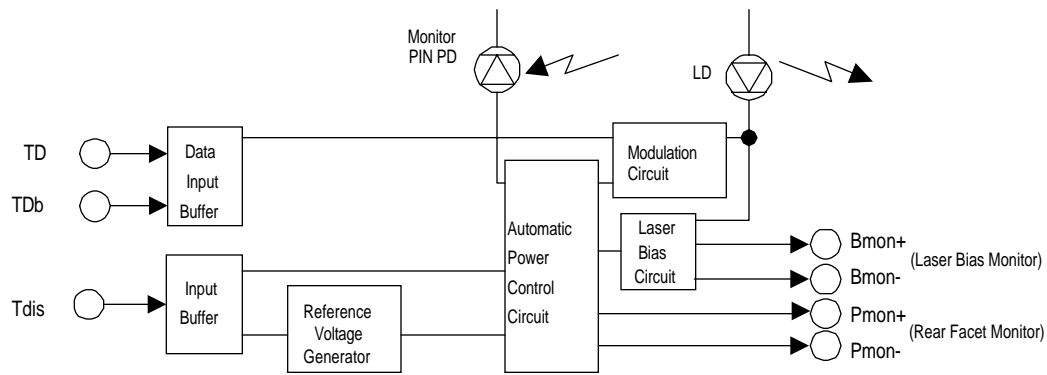

Figure 1-1. Block Diagram (Transmitter)

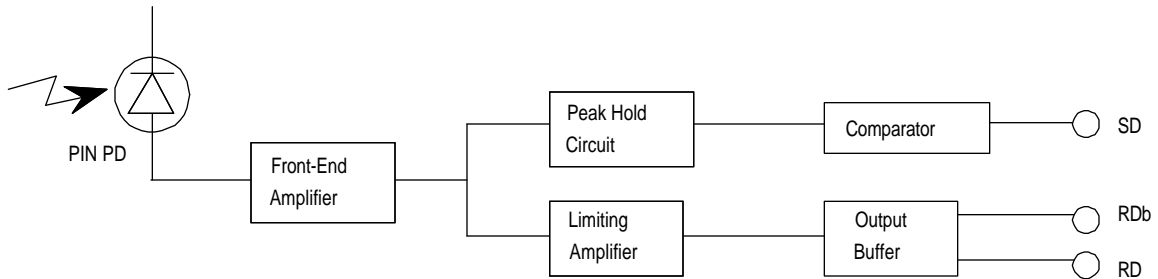

Figure 1-2. Block Diagram (Receiver)

### Caution



Do not disassemble this product. Otherwise, failure, electrical shock, overheating or fire may occur.  
Handle the lead pins carefully. Use assisting tools or prospective aids as required. A lead pin may injure skin or human body

### 3. Package Dimension

All dimensions are in mm.

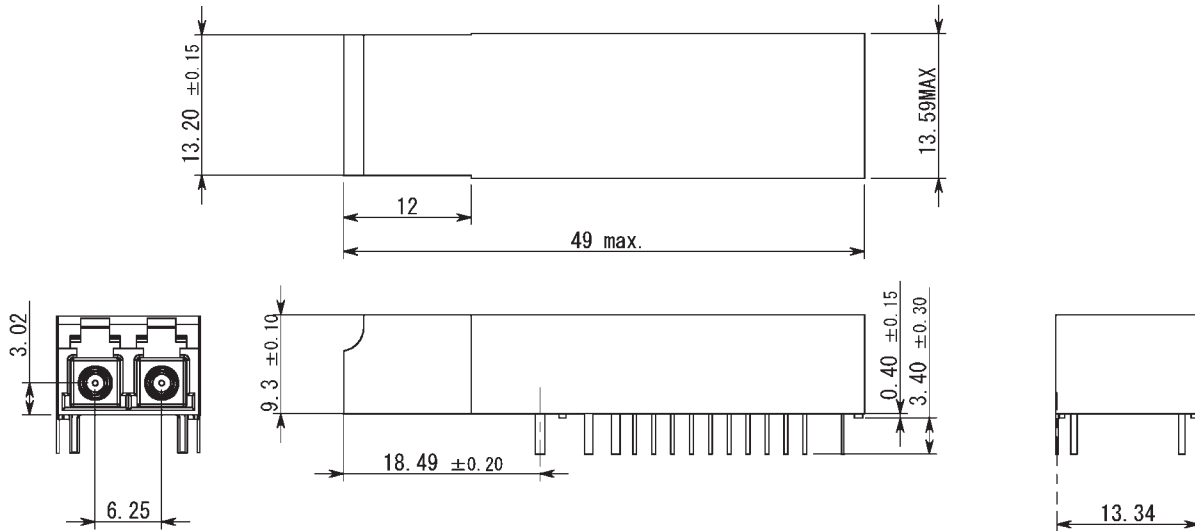

Figure 2-1. Outline Dimensions(SCM6011-GL-ZN)

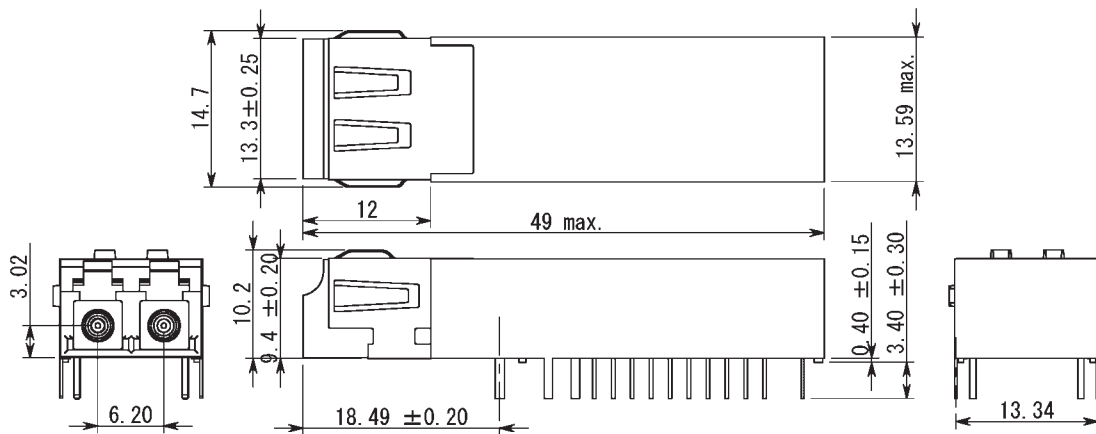

Figure 2-2. Outline Dimensions (SCM6011-GL-CN)

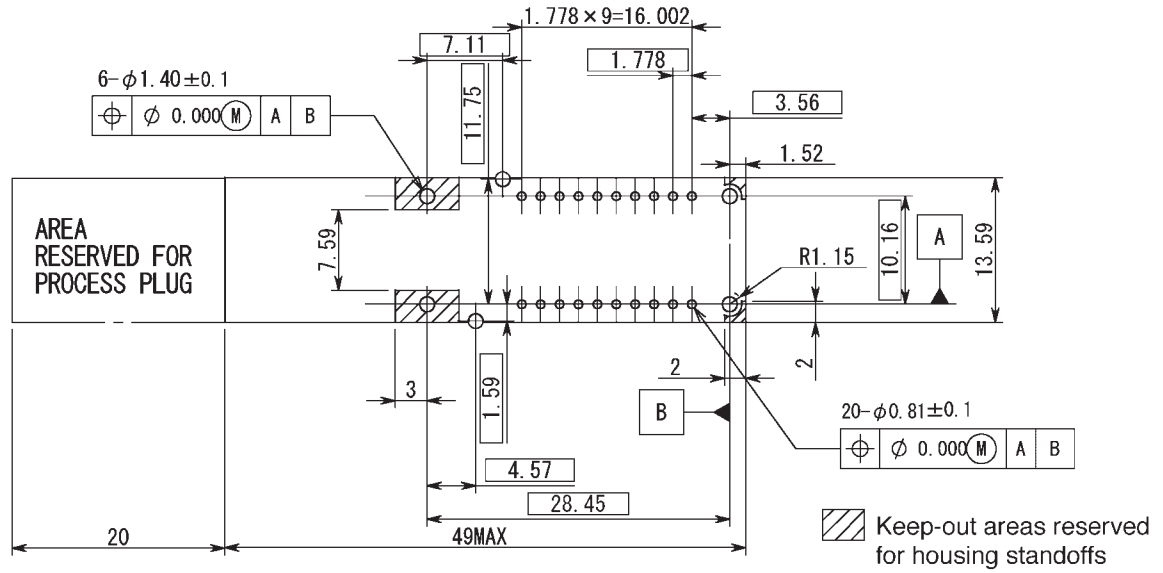

Figure 2-3. Recommended Footprint

## 4. Pin Assignment

No.	Symbol	I/O/P	Level	Description
1	VpdR	P	+3.3V DC	<b>DC Bias Supply for Receiver PIN-PD.</b>
2	VeeR	P	GND	<b>Power Supply (-) for Receiver.</b>
3	VeeR	P	GND	<b>Power Supply (-) for Receiver.</b>
4	NC			<b>No User Connections.</b>
5	NC			<b>No User Connections.</b>
6	VeeR	P	GND	<b>Power Supply (-) for Receiver.</b>
7	VccR	P	+3.3V DC	<b>Power Supply (+) for Receiver.</b>
8	SD	O	LVTTTL	<b>Signal Detect.</b> High level indicates presence of optical input signal (Active High).
9	RDb	O	LVPECL	<b>Inverted Receiver Output Data.</b> No internal terminations are provided.
10	RD	O	LVPECL	<b>Non-Inverted Receiver Output Data.</b> No internal terminations are provided.
11	VccT	P	+3.3V DC	<b>Power Supply (+) for Transmitter.</b>
12	VeeT	P	GND	<b>Power Supply (-) for Transmitter.</b>
13	Tdis	I	LVTTTL/LVCMOS	<b>Transmitter Disable (Active High).</b> Defaults to logic 0 (enable TX) when left open.
14	TD	I	LVPECL	<b>Non-Inverted Transmitter Input Data.</b> Self biased. Not internally terminated.
15	TDb	I	LVPECL	<b>Inverted Transmitter Input Data.</b> Self biased. Not internally terminated.
16	VeeT	P	GND	<b>Power Supply (-) for Transmitter.</b>
17	Bmon-	O	Analog Voltage	<b>LD Bias Current Monitor.</b> Voltage difference between pins 17 and 18 is proportional to the laser bias current.
18	Bmon+	O	Analog Voltage	
19	Pmon-	O	Analog Voltage	<b>Rear Facet Monitor.</b> Transmitter output power can be monitored, in terms of rear facet monitor PD current, by measuring voltage difference between pins 19 and 20.
20	Pmon+	O	Analog Voltage	

Notes:

1. I/O/P stands for signal input, signal output, and DC power/bias supply, respectively.
2. Refer to figure 3 for details of Bmon and Pmon outputs.

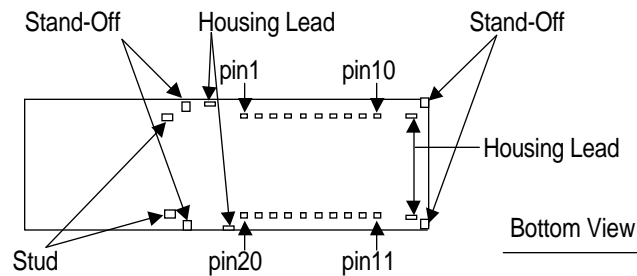

## 5. Absolute Maximum Ratings

Parameter	Symbol	min.	Max	Unit	Note
Storage Case Temperature	Ts	-40	85	°C	1
Operating Case Temperature	Tc	-5	70	°C	
Supply Voltage	Vcc-Vee	0.0	4.0	V	2
Input Voltage	Vi	Vee	Vcc+0.5	V	3
Lead Soldering Conditions	Temperature		260	°C	4
		Time	10	sec.	

Notes:

1. No condensation allowed.
2. Vcc>Vee, Vcc=+3.3V, Vee=GND
3. TD, TDb, Tdis
4. Measured on lead pin at 2mm (0.079in.) off the package bottom

### Warning

Use the product with the rated voltage described in the specification. If the voltage exceeds the maximum rating, overheating or fire may occur.

### Caution

Do not store the product in the area where temperature exceeds the maximum rating, where there is too much moisture or dampness, where there is acid gas or corrosive gas, or other extreme conditions. Otherwise, failure, overheating or fire may occur.

## 6. Electrical Interface

( Unless otherwise specified,  $V_{cc}-V_{ee} = 3.14$  to  $3.47$  V and all operating temperature shall apply. )

### 6-1. Transmitter side

Parameter	Symbol	min.	Typ.	Max.	Unit	Note
Supply Voltage	$V_{cc}-V_{ee}$	3.14	3.30	3.47	V	
Supply Current	$I_{dtx}$		70	150	mA	1, 2, 3
TD, TDb Input Voltage	High	$V_{ih}$	$V_{cc}-1.17$	$V_{cc}-0.73$	V	4, 5
	Low	$V_{il}$	$V_{cc}-1.95$	$V_{cc}-1.45$	V	
TD, TDb Input Current	High	$I_{ih}$	-10	150	$\mu$ A	4, 5
	Low	$I_{il}$	-10	10	$\mu$ A	
Signal Input Rise / Fall Time				1.5	nsec.	6
Tdis Input Voltage	High	$V_{di}$	$V_{ee}+2.0$	$V_{cc}$	V	7
	Low	$V_{ei}$	$V_{ee}$	$V_{ee}+0.8$	V	
Tdis Input Current	High	$I_{di}$	-10	200	$\mu$ A	
LD Bias Monitor Voltage	$V_{bm}$	0.01	0.05	0.50	V	5, 8

Notes:

1. Input bias current is not included.
2. 50% duty cycle data.
3. 155.52Mbps, PRBS2<sup>23</sup>-1, NRZ.
4.  $V_{cc}-V_{ee}=3.3$ V.
5.  $T_c=25^\circ$ C.
6. 20-80%.
7. Refer to Section 8, "Relation between Disable Input Voltage and Optical Output Power", for detail.
8. The Laser Bias Monitor Current and Rear Facet Monitor Current are calculated as ratios between the corresponding voltages and current sensing resistors, 10 $\Omega$  and 200 $\Omega$ , as shown in the figure 3.

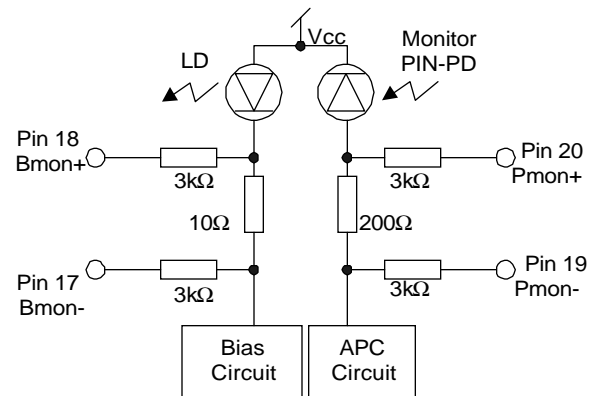

Figure 3 Bmon and Pmon Interface

### 6-2. Receiver side

Parameter	Symbol	min.	Typ.	Max.	Unit	Note
Supply Voltage	$V_{cc}-V_{ee}$	3.14	3.30	3.47	V	
Supply Current	$I_{drx}$		80	140	mA	1
RD, RDb Output Voltage	High	$V_{doh}$	$V_{cc}-1.10$	$V_{cc}-0.86$	V	2
	Low	$V_{dol}$	$V_{cc}-1.86$	$V_{cc}-1.62$	V	
SD Output Voltage	High	$V_{soh}$	$V_{ee}+2.20$	$V_{cc}$	V	
	Low	$V_{sol}$	$V_{ee}$	0.5	V	
Data Rise / Fall Time	$T_{rd} / T_{fd}$			1000	psec.	3
SD Assert Time	$T_a$	2.3		100	$\mu$ sec	4
SD Deassert Time	$T_d$	2.3		100	$\mu$ sec	

Notes:

1. Output current is not included. 155.52Mbps, PRBS2<sup>23</sup>-1, NRZ.
2.  $V_{cc}=+3.3$ V,  $T_c=25^\circ$ C. Output load resistance  $R_l=50\Omega$  to  $V_{cc}-2$ V for RD, RDb.
3. 20-80%. Input capacitance and stray capacitance of measuring devices should be less than 2pF.
4. 155.52Mbps, PRBS2<sup>23</sup>-1, NRZ.

## 7. Optical Interface

( Unless otherwise specified, Vcc-Vee = 3.14 to 3.47 V and all operating temperature shall apply. )

### 7-1. Transmitter side

Parameter	Symbol	min.	Typ.	Max.	Unit	Note
Average Output Power	Po	-5.0	-2.0	0.0	dBm	1
Extinction Ratio	Er	8.2			dB	1
Center Wavelength	$\lambda_c$	1280		1335	nm	
Spectral Width (RMS)	$\Delta\lambda$			1.0	nm	
Eye Mask for Optical Output	Refer to Figure 4					

Notes:

1. Measured at 155.52Mbps PRBS2<sup>23</sup>-1

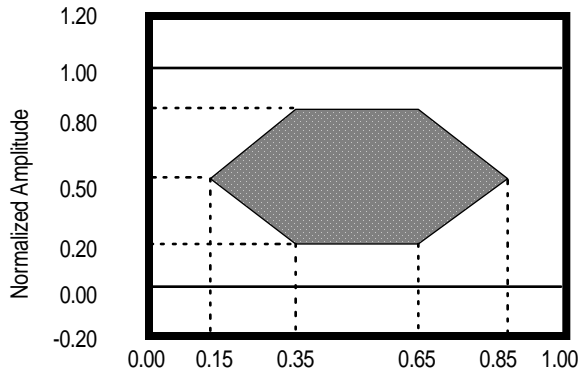

Relation between Input Signal and Optical Output Signal

Input Signal		Optical Output Signal
TD	TDb	
High	Low	ON (High)
Low	High	OFF (Low)
High	High	Undefined
Low	Low	Undefined

Figure 4 Optical Pulse Mask with Fourth Order Bessel-Thomson Filter Specified in ITU-T G.957

### ⚠ Warning



Do not look at the laser beam projection area (e.g. end of optical connector) with naked eyes or through optical equipment while the power is supplied to this product. Otherwise, your eyes may be injured.

### 7-2. Receiver side

Parameter	Symbol	min.	Typ.	Max.	Unit	Note
Optical Input Wavelength	-	1261		1580	nm	
Minimum Sensitivity	Pmin		-35.0	-34.0	dBm	1, 2
Overload	Pmax	-8.0			dBm	1, 2
SD Assert Level	Pa		-37		dBm	2
SD Deassert Level	Pd		-40		dBm	
SD Hysteresis	Phys		3		dB	

Notes:

1. BER=10<sup>-10</sup>

2. Measured at the bit rate of 155.52Mbps, PRBS 2<sup>23</sup>-1, NRZ

## 8. Relation between Disable Input Voltage and Optical Output Power

Tdis Input Voltage	Optical Output Power
"L"(Vee ~ Vee+0.8V)	Enabled
"H"(Vee+2.0V ~ Vcc)	Disabled (<-45dBm)
Open	Enabled

## 9. Recommended Interface Circuit

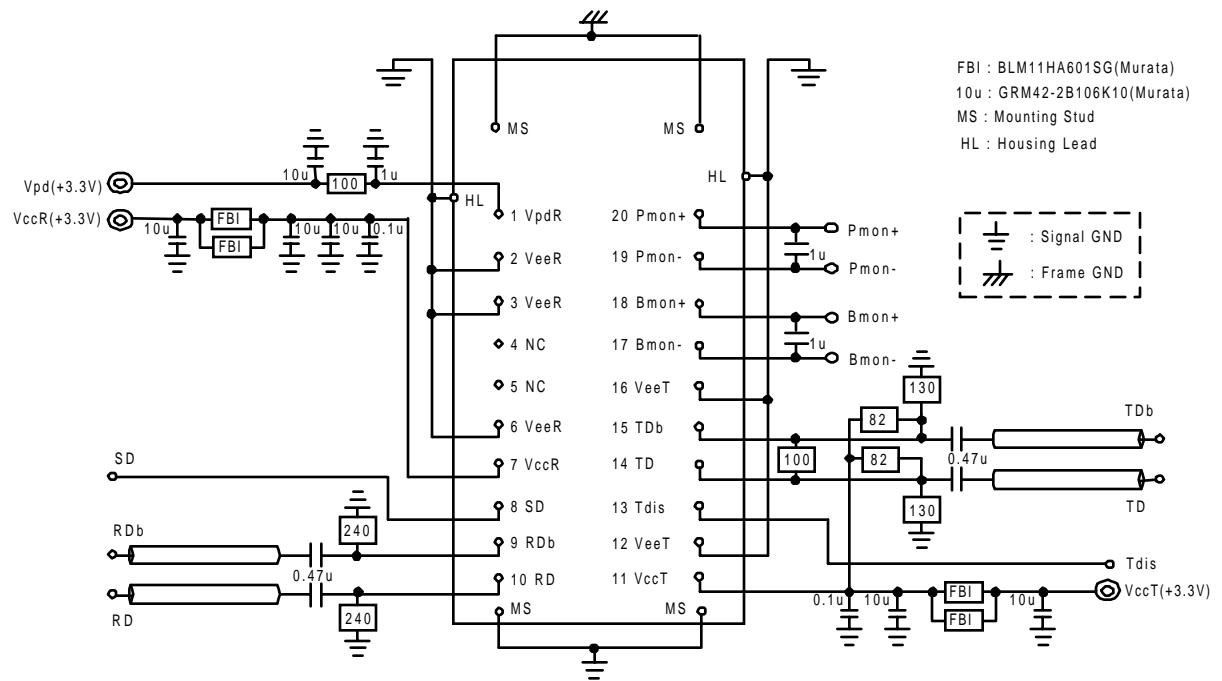

Figure 5. Recommended Interface Circuit

## 10. Reliability Test Program

GR-468-CORE Issue 1, December 1998 Laser Module

HEADING	TEST	REFERENCE	CONDITIONS	SAMPLING		
				LTPD	SS	C
Mechanical Integrity	Mechanical Shock	MIL-STD-883 Method 2002	5 times/ axis 1,500G, 0.5ms	20	11	0
	Vibration	MIL-STD-883 Method 2007	Cond. A 20G, 20-2,000G Hz, 4min/ cy, 4cy/axis	20	11	0
	Thermal Shock	MIL-STD-883 Method 1011	Delta T=100degC 0degC to 100degC	20	11	0
	Solderability	MIL-STD-883 Method 2003	(steam aging not required)	20	11	0
Endurance	Accel. Aging (High Temp.)	(R)-4-53 Section 5.18	85degC; rated power 1,000 hrs. for pass/ fail 2,000, 5,000 hrs. for info.	-	25 10	-
	Low Temp. Storage	-	min, storage T 1,000 hrs. for pass/ fail 2000 hrs. for info.	20	11	0
	Temperature Cycling	Section 5.20	-40degC to +85degC 500 for pass/ fail 1,000 for info.	20 -	11 11	0 -
	Damp Heat	MIL-STD-202 Method 103 or IEC-68-2-3	85degC/ 85%RH 1,000hrs.	20	11	0
	Cyc. Moist., Res.	Sec. 5.23	-	20	11	0
Special Tests	Internal Moisture	MIL-STD-883 Method 1018	Max. 5,000ppm water vapour	20	11	0
	ESD Threshold	Section 5.22	-	-	6	-

SS : Sample Size

C : Maximum number of failure allowed to pass the test.

## 11. Laser Safety

This product uses a semiconductor laser system and is a laser class 1 product acc. FDA, complies with 21CFR 1040. 10 and 1040.11. Also this product is a laser class 1 product acc. IEC 825-1.

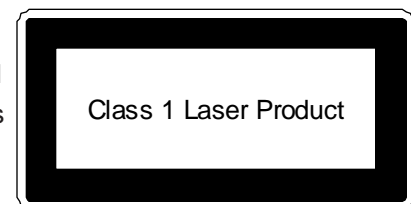

### Caution





If this product is used under conditions not recommended in the specification or this product is used with unauthorized revision, classification for laser product safety standard is invalid. Classify the product again at your responsibility and take appropriate actions.



## 12. Other Precaution

Under such a strong vibration environment as in automobile, the performance and reliability are not guaranteed.

The governmental approval is required to export this product to other countries. To dispose of these components, the appropriate procedure should be taken to prevent illegal exportation.

This module must be handled, used and disposed of according to your company's safe working practice.

 <b>Warning</b>	
	Be sure to carry out correct soldering for connection to peripheral circuits in order to prevent contact failure or short-circuit. Otherwise, a strong laser beam may cause eye injury, overheating or fire.
	Do not put this product or components of this product into your mouth. This product contains material harmful to health.

 <b>Caution</b>	
	Be sure to turn the power off when you touch this product connected to the printed circuit boards. Otherwise, electric shock may occur.
	Dispose this product or equipment including this product properly as an industrial waste according to the regulations.

## 13. Ordering Information

Ordering Number	Connector Type	EMI Shield Finger Option	Operating Case Temperature
SCM6011-GL-ZN	LC Duplex Receptacle, Metallized	Without Finger	-5°C ~ 70°C
SCM6011-GL-CN	LC Duplex Receptacle, Metallized	With Type-C Finger	

## 14. For More Information

### U.S.A.

Sumitomo Electric Lightwave Corp, 78 Alexander Drive, Research Triangle Park, NC 27709

Tel. +1-919-541-8100 / Fax. +1-919-541-8376

E-mail: [info@sumitomoelectric.com](mailto:info@sumitomoelectric.com)

<http://www.sumitomoelectric.com/products/eop>

### Europe

Sumitomo Electric Europe Ltd., 220, Centennial Park, Elstree, Herts, WD6 3SL, United Kingdom

Tel. +44-208-953-8681

Fax. +44-208-207-5950

### Japan

Sumitomo Electric Industries, Ltd. ( International Business Division ), 3-12, Moto-Akasaka 1-chome  
Minato-ku Tokyo 107-8468

Tel. +81-3-3423-5771 / Fax. +81-3-3423-5099

E-mail: [product-info@ppd.sei.co.jp](mailto:product-info@ppd.sei.co.jp)

<http://www.sei.co.jp/Electro-optic/index.html>